

PARAJET SAFETY ADVISORY BULLETIN

AUGUST 2024 - MAV MAX 12.5L FUEL TANK



Please read and follow this safety advisory bulletin thoroughly before undertaking further product use or flight. This advisory bulletin contains important safety information and disregarding these precautions could cause serious injury or death.

We have produced the following safety bulletin as part of our commitment to our customers' safety and continued enjoyment of our sport.

To ensure the continued safe operation and optimal configuration of your equipment, please continue reading to the end of this document. By receiving this safety bulletin, you will be taken to have read and understood it in full.

In addition, all pilots are reminded of the importance of carrying out comprehensive pre and post flight checks of their paramotoring equipment and this safety advisory bulletin has been issued to inform pilots of recommended additional safety measures that must be undertaken.

PRODUCT

Parajet 12.5L Fuel Tank [PJ-A-11655]



SITUATION/CONCERN

We have received a report of a cracked 12.5L Mav Max fuel tank, specifically around the inset for the battery back plate. Cracking in this area has resulted in fuel seeping when the tank is tilted forwards or filled above the 10L level.

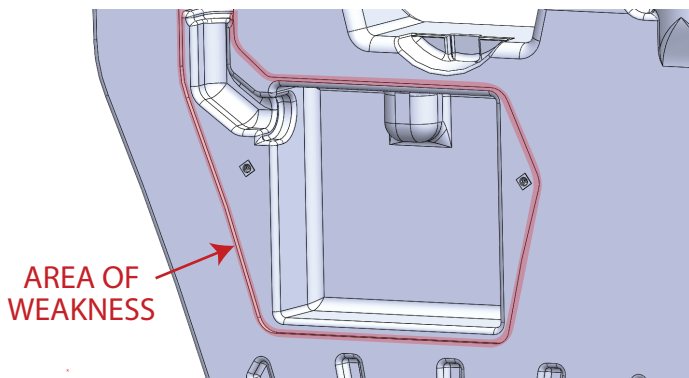

SOLUTION/PROCEDURE

With this in mind and with safety always being a top priority, we are issuing the following safety advice to all Mav Max customers currently using the 12.5L size fuel tank:

Please take note of the advisory and ensure you monitor the tank in this area prior to and after every flight. Should you experience any issue or be concerned in any way, please do not fly and immediately contact us at info@parajet.com so that we may assess the situation and confirm if we believe the tank is effected and should be replaced.

NB. The 16.5L size fuel tank is not affected by this advisory as several upgrades were made during design process, including a chamfered edge, re-enforcement of material around the plate area, and a newly sized plate to allow for less stress. As a result, any 12.5L tanks effected will be replaced by the larger 16.5L size to ensure customers can have total peace of mind.

FURTHER ASSISTANCE

As ever, we continue to encourage all customers to remain vigilant with their pre and post flight checks, and if ever in any doubt, to please not fly and first notify us to ensure we can provide an assessment and any assistance you made need to ensure your equipment remains in a safe and optimal condition.